

MODEL SPECIFICATION

Metrotile Bond 450

Open Rafters

Eaves Fascia Tray (optional)

Fit Metrotile Eaves Fascia Tray into roof overhang and gutter, and fix to rafters using galv. clout-head nails.

When using Eaves Fascia tray it is not necessary for underlay to continue over into gutter, but it should form a headlap over the eaves fascia tray.

Underlay - Wooden Rafters

Min. BS747:type 1F or 5U reinforced sarking felt, laid in accordance with BS5534: Part 1, and fixed to rafters with 20mm galvanised felt nails, not less than 3.0mm dia. shank.

Felt Lap Chart (BS5534)

Pitch	Headlap	Sidelap
Up to 12 Degrees	300mm minimum	100mm minimum
12 - 14 Degrees	225mm minimum	100mm minimum
15 - 34 Degrees	150mm minimum	100mm minimum
Over 35 Degrees	100mm minimum	100mm minimum

Battens - Wooden Rafters

Softwood battens & counterbattens to be in accordance with BS5534 and treated with a non-copper based preservative, cut ends to be treated in situ.

Treated tiling battens, section to suit rafter spacings (see chart), to be laid at 370mm gauge except for eaves batten which should be positioned with front face 330mm from front of fascia, and top course batten which should be 370mm or less to cater for exact rafter length. Battens fixed to rafters using galv. twist or annular ring shank nails (see chart). Joints in battens to be staggered and centred on face of rafters.

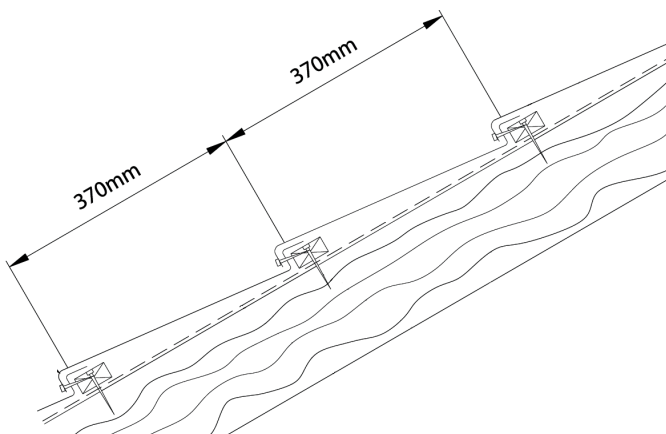

Batten Sizes

Rafter Centre	Batten Size	Nail Size
Up to 600mm	50 x 25	75 x 3.35
900 - 1200mm	50 x 50	100 x 4mm

On rafter centres greater than 900mm additional support to the underlay can be provided by stretching polypropylene, or other rotproof, tape horizontally and stapling to the front face of the rafters.

Steel Frame

Battens - Steel frame

Create counterbattens by positioning lengths of 50 x 50mm tiling batten vertically up-pitch at 1200mm cs. and fixing to either purlins or tilt frame, using self drill/self tap screws or (wood to metal screws) in accordance with manufacturers instructions.

Underlay felt, and support tapes can then be fixed to these counterbattens and then 50 x 50mm tiling battens, spaced as for wooden rafters.

Counter battens – Boarded Roof

50 x 25mm treated softwood counterbattens to be fixed over sarking boards immediately above, and at same centres as, the rafters, and fixed with 100 x 4mm galv. twist or annular ring shank nails.

Underlay – Boarded Roof

Min. BS747: type 1F felt to be laid over counterbattens, draped between same without stretching, and fixed with 20mm galv. felt nails. Felt laps to be in accordance with BS5534:part 1

Felt Lap Chart (BS5534)

Pitch	Headlap	Sidelap
Up to 12 Degrees	225mm minimum	100mm minimum
12 - 14 Degrees	150mm minimum	100mm minimum
15 - 34 Degrees	100mm minimum	100mm minimum
Over 35 Degrees	75mm minimum	100mm minimum

Battens - Boarded Roof

Treated s/wood battens, section to suit rafter spacings (see chart), to be laid at 370mm gauge and fixed to counterbattens using galv. twist or annular ring shank nails (see chart). Batten joints to be staggered and centred on face of counterbattens.

MODEL SPECIFICATION

Tiles

Metrotile 450 lightweight roofing tiles 1257 x 370mm coverage laid onto tiling battens and fixed through nose of tile into front face of batten, using 4 no. Metrotile cement coated, galvanised fixing nails per tile strip. Nails to be positioned 50mm from tile pan centres.

Where necessary, the top course of tiles to be cut to size in situ, and cut edge to be bent to form a 25mm upstand against the ridge batten.

Quality

Tiles and accessories must comply with ISO 9001 and possess European Agreement certification.

The core of each tile to be formed from 0.45mm nom. thickness, AZ185 - drawing quality grade 3 steel, with Aluzinc® (55% aluminium/45% zinc) & primer protection applied to both surfaces. The weather side of the tile to have the following additional coatings, consisting of:

- A coloured acrylic base coat
- Natural stone chip granules
- A clear acrylic overglaze

Ridge - Square

25mm thick ridge board extension to project 70mm above height of tiling battens.

Top course of tiles to be cut to size, and bent in situ to form a min. 25mm upstand against edge of ridge board.

Square ridge cap to be positioned over ridge board and tile upstands, and fixed with Metrotile nails through sides of cap and tile upstand, into sides of ridge board -four Metrotile nails to be used each side.

Ridge - Angle Cap (10-45 deg.)

Topcourse batten to be fixed either side of ridge line and a further 25mm thick treated s/w batten of suitable width, to be fixed on edge to upper edge of the topcourse batten, to form a 25mm upstand above the height of same.

Top course of tiles to be cut to size and bent in situ to form a 25mm upstand against the vertically projecting face of this perpendicular batten.

The Angle Ridge Cap to be positioned over both the perpendicular batten and the tile upstands, and fixed through the cap sides and tile upstand, into the side of the perpendicular batten, using four Metrotile nails for each side of 1200mm long ridge cap.

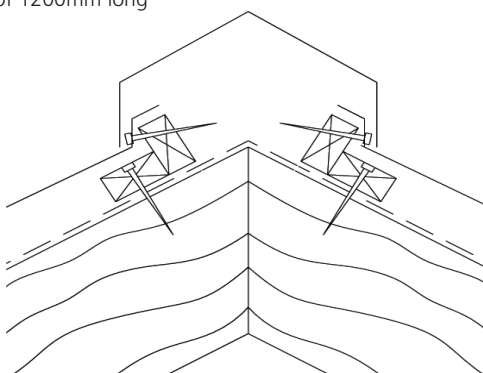

Ridge - Delta Cap (10-25 deg.)

Two further tiling battens (one placed atop the other) to be fixed to rafters (either side of ridge) abutting the topmost edge of the topcourse batten.

Top course of tiles to be cut to size and bent in situ to create a 25mm upstand at top edge of tile.

Position tile so that the 25mm upstand abuts the double row of battens at ridge.

Place Delta Ridge Cap over double batten and tile upstand and fix through side of cap and upstand, into side of double ridge batten. Use four Metrotile nails for each side of 1200mm long Delta Cap.

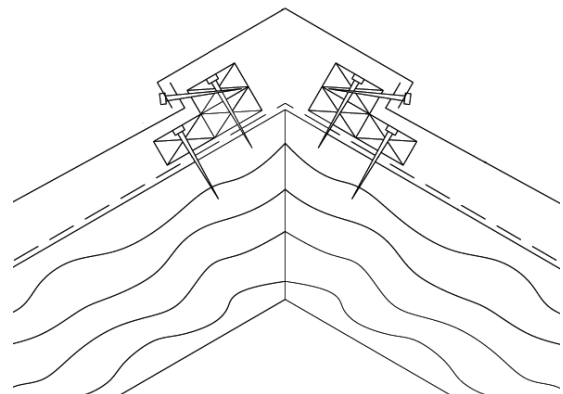

Ridge - Delta Ventilated

Form ridge batten by nailing additional tiling batten alongside upper edge of topcourse batten, and ensure that underlay is cut through along ridge line to form 5mm continuous air gap either side of ridge line. Cut top course of tiles to size and bend upper edge to form 25mm upstand.

Position top course of tiles over top and ridge battens, ensuring that there is 10mm continuous air gap between tile upstand and upstand of top row of tiles on opposing pitch.

Position ridge ventilation tray (min. 5mm cont. ventilation) on tile, over ridge batten, and place another tiling batten inside tray. Fix this upper ridge batten in place through tray and lower ridge batten.

Install Delta Ridge Cap in place over the upper ridge battens and fix with .5 Metrotiles nails through each side of cap, into side of upper ridge batten.

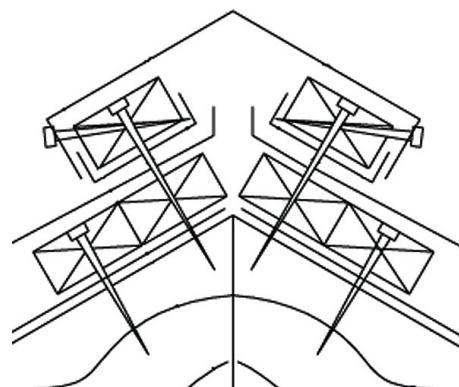

MODEL SPECIFICATION

Eaves

Underlay should be draped over fascia, into gutter, and fixed in such a manner that moisture can drain over the fascia, into the gutter (use tilting fillets or layboards if necessary).

Front edge of eaves batten should be 330mm from front edge of fascia, to allow for eaves overhang into gutter.

Top edge of fascia should be in line with top edge of tiling battens.

The eaves course of tiles should be positioned so that the nose of the tiles projects 40mm beyond the front face of the fascia board.

The lower edge of the tile should be face fixed to upper edge of fascia board using 4 no metrotile nails through higher point of tile profile (at no point should nails penetrate the lower parts of the tile profile). Treat nail heads with Metrotile paint and grit.

Where the fascia board cannot accept a fixing, a tiling batten should be fixed to the rafters, immediately behind the fascia boards, and the tile nails fixed to this batten.

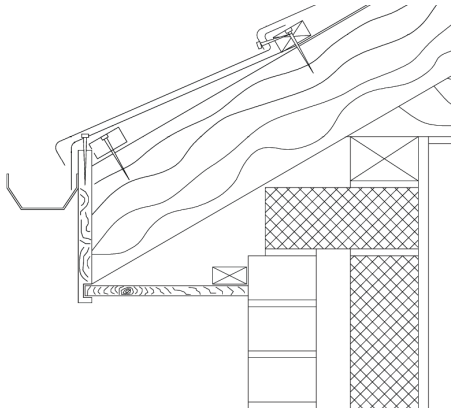

Eaves - Ventilated

The top of the eaves fascia board should be fixed in line with the top of the tile battens, minus the depth of the appropriate eaves vent.

A continuous eaves vent should be fixed to the top of the fascia board (10mm continuous ventilation for roofs over 15 deg. pitch, 25mm for roofs below 15 deg. pitch, or where the line of insulation/soffit is parallel to the pitch).

An additional tiling batten should now be fixed at the eaves, set back to allow a min 25mm gap between its lower edge and the upper edge of the continuous vent strip.

The underlay should be draped over this batten, and the eaves vent, into the gutter. If necessary fit layboard and/or tilting fillets to ensure moisture drains over this batten and the vent, into the gutter.

Install eaves course ensuring nose of tile projects 40mm beyond fascia, and face fix into setback eaves batten using four Metrotile nails per tile strip. Nail heads to be treated with Metrotile paint and grit.

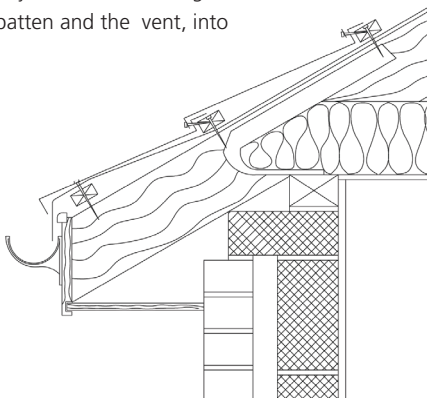

Gable End Verge

Fix bargeboard so top edge is 50mm above top edge of tiling battens.

Bend tiles to form 25mm upstand against edge of bargeboard & fix in position on tiling battens.

Position handed barge cap overlapping outer edge of bargeboard, and lapping over tile edge and upstand.

Fix each cap using four Metrotile nails horizontally through outer edge, and three vertically into top edge of bargeboard. Vertical nail heads should be treated with Metrotile paint and grit.

Hip - Square Cap

From 25mm thick treated softwood from hip board extension projecting 70mm above hip line.

Cut adjacent tiles on rake and bend to form 25mm upstand and install tiles with this upstand abutting the sides of the hip board.

Place Square Hip Cap over hip board and tile upstands and fix through side of cap and upstands, into side of hip board. Use four Metrotile nails for each side of hip cap.

Hip - Delta Cap

Position hip battens parallel, either side of hip line, using Delta Hip Cap as spacing template, and fix in place over tiling battens.

Cut adjacent tiles on rake and bend to form 25mm upstand at rake. Fix tiles onto tiling battens with upstand abutting hip battens.

Position Delta Hip Caps in place, over hip battens and tiles upstands, and fix through side of cap and upstand, into side of hip batten, using four Metrotile nails per each side of 1200mm cap.

Hip - Delta Cap, Ventilated

Fix parallel hip battens, over tiling battens and either side of hip line, using Delta Hip Cap as template.

Carefully cut sarking felt along hip line, leaving a 10mm min cont. gal along hip line.

Cut adjacent tiles on the rake and bend the cut edge to form a 25mm min upstand.

Fix tiles in place with tile upstand abutting outer face of hip batten, and fit Metrotile Universal Vent strip (min. 5mm cont. ventilation) in place over tile against the upstand.

Position Delta hip cap in place, over hip battens and universal vents, and nail through side of cap (4 Metrotile nails per each side of 1200mm cap)

MODEL SPECIFICATION

Valleys

Valley lining to be formed in situ from lead, or pre-formed from metal sheet or GRP, and supported on layboards or noggins.

Terminate tiling battens over valley flashing at a suitable distance to oversail the flashing and with batten ends parallel to the valley line. Valley opening dependent on roof pitch and rainfall, to comply with BS5534:2003 part 6.1.1.

(When using valley battens spring the tile battens over these, using spacers on the adjacent jack rafters if necessary).

Ensure underlay drapes well into valley, over valley lining and/or valley battens.

Tiles adjacent to the valley to be cut on the rake and bent down in situ, to form a min. 25mm downturn into the valley.

Abutments

Tile to be cut and bent in situ to form 75mm upstand against vertical abutment. Lead cover flashing to be installed into abutment, min. 150mm height, and draped over tile upstand.

Roof Penetrations - Tile Vents

Metrotile Standard roof vent provides 7500sq.mm. of ventilation, Metrotile In-Line roof vent provides 10,000sq.mm. ditto.

Vent weir plate edges should be taped to underlay, and latter cut away at aperture for penetration of the felt sleeve..

Position vent tile on tiling battens, with felt sleeve projecting through weir plate, and fix in place with Metrotile nails through nose in to side of tiling batten (ensuring that the adjacent tiles lap over the vent tile on both sides).

Roof Penetrations - Soil Vents

Terminate soil vent pipe within roof space, and install Metrotile Standard or In-line Roof vent above and in close proximity to pipe termination. Connect and secure flexi-hose to tile vent felt sleeve, and soil pipe termination.

Roof Penetrations - Rising Pipes

Cut underlay and tape around rising pipe. At appropriate point carefully cut an aperture in the tile, large enough to allow the rising pipe to pass through, and install using a traditional lead slate and collar to seal the joint between the pipe and tile. Ensure the lead slate sits on top of the surrounding tile surface, up under the nose of the tile course above, and down over the nose of the tile course below.

Alternatively a proprietary pipe flashing, such as Dektite, can be used in accordance with the manufacturers instructions.

Roof Penetrations - Ridge Gas Vent

Install using industry standard R type adaptor, supplied by others (only for use with Delta ridge cap).

Roof Penetration - Metrotile Roof Window

Using wooden noggins, and cutting rafter where necessary, create aperture in roof structure, flush with rafter top and 5mm per side larger than roof window frame. Insert window into aperture so that horizontal groove in outer sides of window frame are 10mm higher than rafter surface, and secure using vertical fixing straps provided.

Install roof window flashing and adjacent tiles, cutting the latter in situ to ensure they project over the double channel in the flashing sides.

Roof Penetrations - Solatube

Carefully cut felt to allow passage of Solatube, creating a felt lap which should be taped to the body of the Solatube when in position.

Place top section of Solatube in position on battens and nail through nose of fitting, as for normal Metrotile, ensuring that the adjacent Metrotile units overlap the Solatube flange on both sides.